

## iN Series Embedding Guide

The Xerafy iN Series of RFID-in-metal tags can be embedded during pre or post-production of metallic assets. This installation guide provides suppliers and users the best mounting techniques for optimal read performance. Xerafy can provide tag modifications to solve specific needs for applications that require customization.

To properly embed iN tags, you must prepare a socket to meet the dimensions shown in the socket dimension figures on Page 2 of this guide. A circular cut cavity is optimal for signal range and radiation pattern due to the radial nature of the radio frequency signal. It is important to ensure a flat metallic surface is used to eliminate gaps from the tag to the metal surface as air gaps can lower the read range by detuning the tag.

Create a socket hole in the metal asset you wish to tag. Socket sizes are determined by the type of iN tag used. After a socket has been created, make sure to clean the surface of the socket.

To attach the tag to the surface, apply epoxy to the bottom of the tag and place the tag in the socket (Step 1). Make sure to position the tag in the center of the socket (Step 2).

After the epoxy is cured the remaining socket space around the tag can be filled with a resin that does not contain any metallic ingredients such as 3M Scotchcast™ Electrical Resin 281 (Step 3). Make sure to fill in any gaps around the tag (Step 4). Once the resin has properly cured, the tag will be readable and ready for use (Step 5).



### Step 1

Apply epoxy to bottom of tag



### Step 2

Position tag in center of socket



### Step 3

Fill in socket with resin

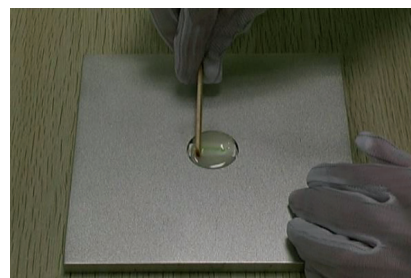

### Step 4

Make sure to fill any gaps between tag and socket wall



### Step 5

Allow resin to cure and tag is ready for use

# Socket Dimensions for Flush-mounting Tags

## Pico-iN

Tag dimensions	0.47 x 0.28 x 0.12 in (12 x 7 x 3 mm)
Tag weight	0.05 oz (1.4 g)
Socket hole dimensions	0.59 x 0.13 in (15 x 3.3 mm)

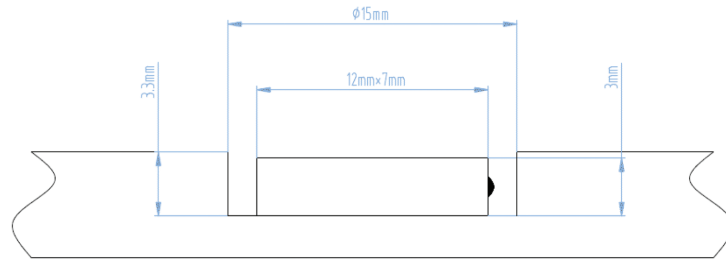

## Nano-iN

Tag dimensions	0.98 x 0.35 x 0.12 in (25 x 9 x 3 mm)
Tag weight	0.14 oz (4 g)
Socket hole dimensions	1.10 x 0.13 in (28 x 3.3 mm)

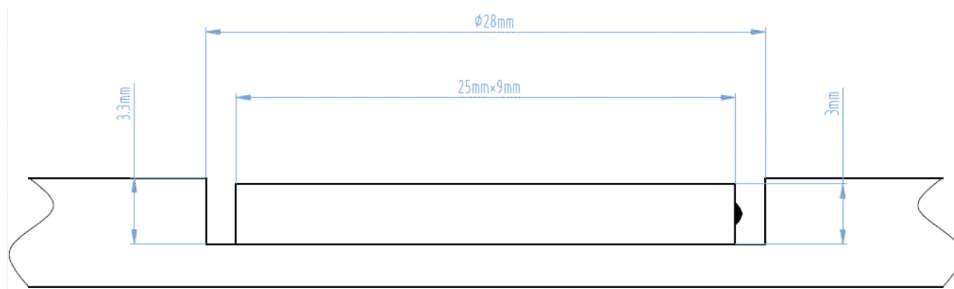

## Micro-iN

Tag dimensions	1.18 x 1.18 x 0.12 in (30 x 30 x 3 mm)
Tag weight	0.53 oz (15 g)
Socket hole dimensions	1.77 x 0.13 in (45 x 3.3 mm)

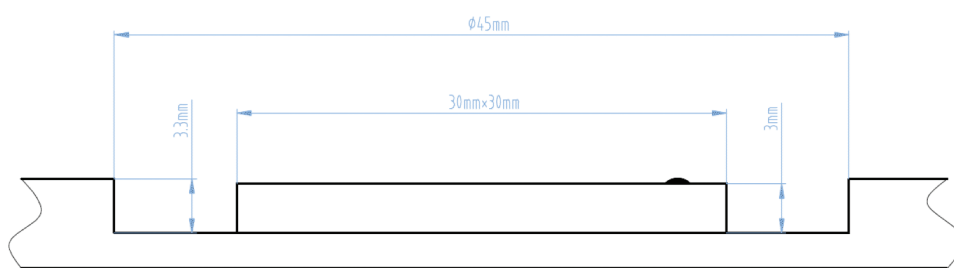

# Cylindrical Socket Mounting Diagram

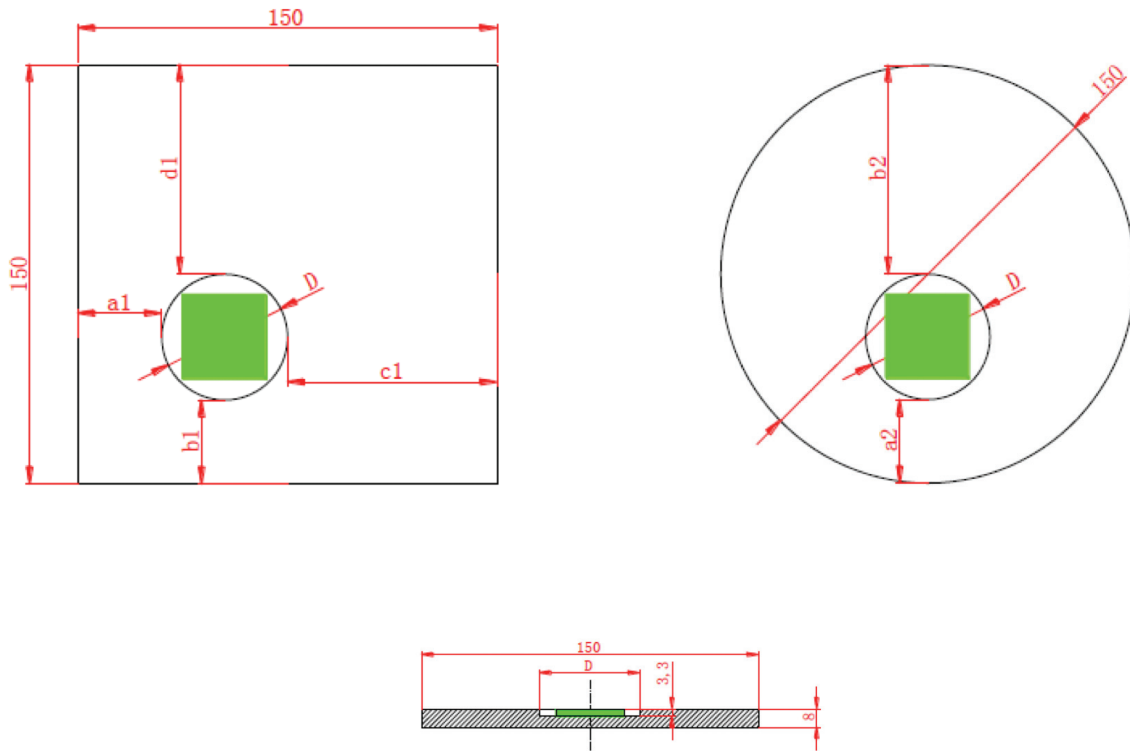

**Pico-iN:**  $a_1, b_1, c_1, d_1, a_2, b_2 \geq 0.79$  in (20 mm);  $D = 0.59$  in (15 mm)

**Nano-iN:**  $a_1, b_1, c_1, d_1, a_2, b_2 \geq 0.98$  in (25 mm);  $D = 1.10$  in (28 mm)

**Micro-iN:**  $a_1, b_1, c_1, d_1, a_2, b_2 \geq 1.18$  in (30 mm);  $D = 1.77$  in (45 mm)